

Grip-Clamp® 2502, TWO ARM TOGGLE LOCK

ALADCO offers a line of Pneumatic Grip-Clamps® ideal for your particular automotive, food and other industrial manufacturing requirements. Special heat treated alloy steel components offer superior wear and toughness. Adjustable cushions provide smooth, long operation. Standard arms allow for a wide range of tooling clearances. We offer toggle lock and power lock clamps allowing greater flexibility to fit all your manufacturing needs.

Toggle vs Power

The **toggle** clamp is used for added safety and is designed so that the linkage goes over-center and remains in a positive locked position even in the absence of air pressure. The toggle clamp is unlocked only by the cylinder powering the linkage back through the over-center locked position.

The **power** lock is designed so that the linkage does not go over-center providing for variable clamping thicknesses.

We recommend the use of Aladco check valves for toggle and power applications to maintain the air pressure and clamping force.

Features

- The largest gripper available - 10,900 inch-lbs. clamping force
- Grip-Clamp mechanically toggle locks in the over-center clamped position
- Standard 90° arm openings
- Custom arms and special openings available
- Enclosed 1.0" cylinder rod prevents rod failure
- Powered by a 4.00" bore cylinder
- All heat treated, precision ground alloy steel components for reliability
- Grease fittings for relubrication
- NFPA mounting to fit a quality cylinder
- Hydraulic cylinder option available
- Made in the USA

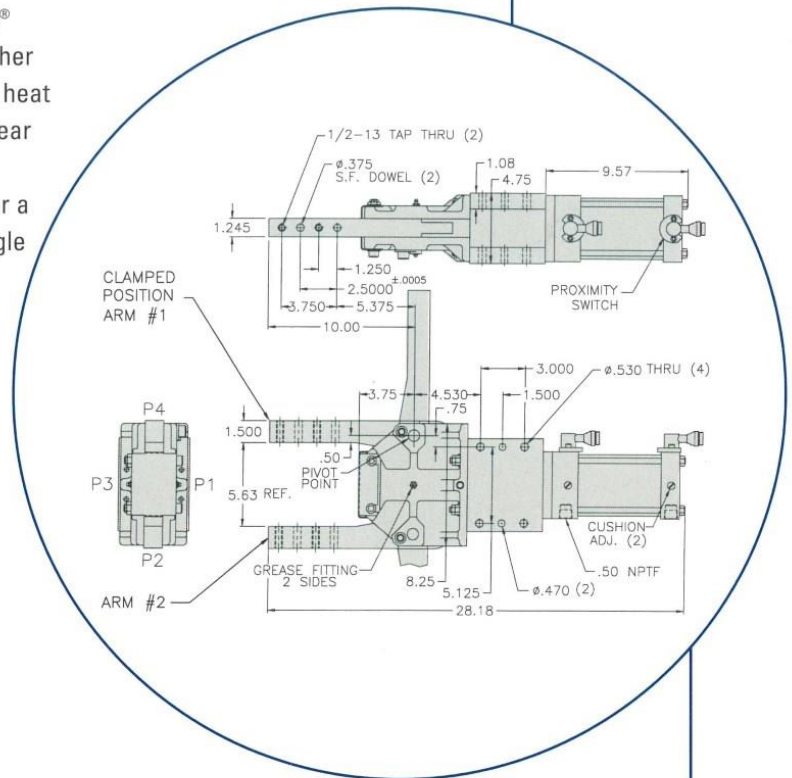

SPECIFICATIONS

Total Weight	Arm Capacity	Arm Rotation	Maximum Pressure	Maximum Temperature
67 lbs	56,800 in - lbs	90°	250 psi	150° F

TOGGLE LOCK CLAMPING FORCES AT 80 PSI

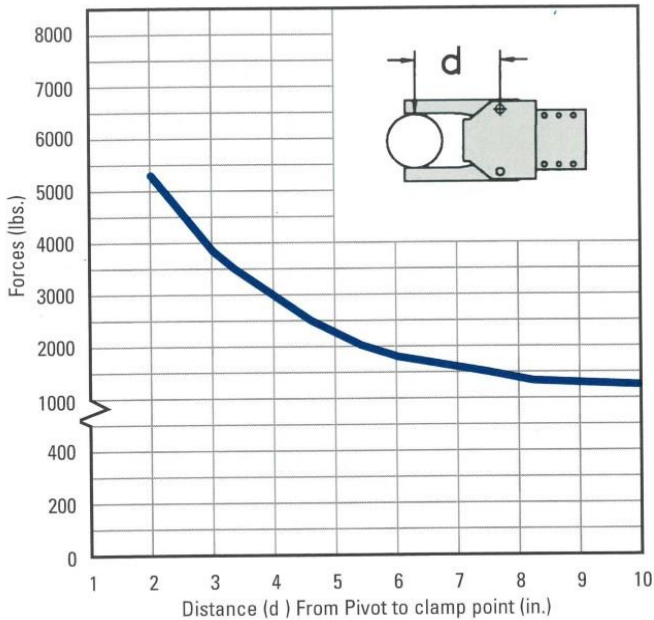

$$\left(\text{Clamping Force} = \frac{10,900 \text{ IN-LBS}}{\text{ARM DISTANCE}} \right)$$

ARM TORQUE AT 80 PSI

(Combined for both arms)

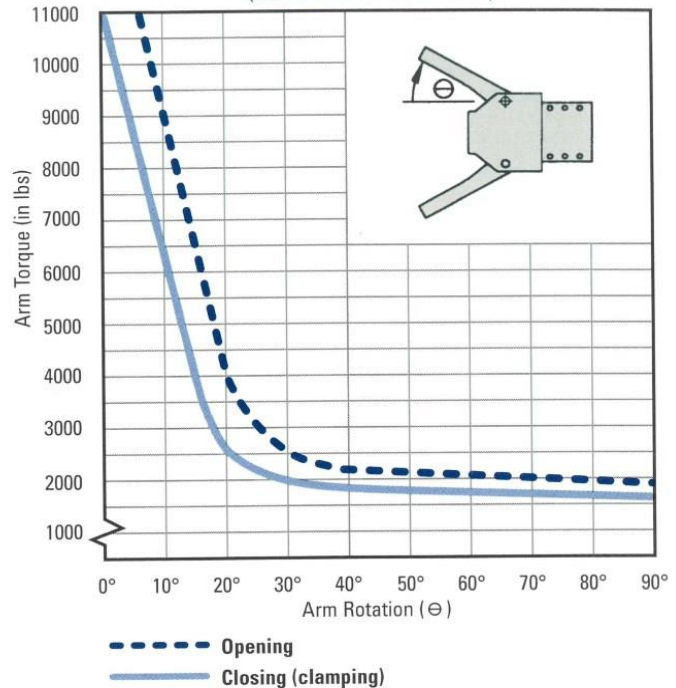

ORDERING INFORMATION

To order please indicate your part number(s) by formulating the desired style number for each of the corresponding areas from the list below. See the sample part number at right.

Body Style	Cylinder Type	Port Position	Switch Option	Arm #1 Option	Arm #2 Option
2502	A01	P2	C1	AS52	AT52

Body Style:

Style	Description
2502	2 Arm Toggle Lock Configuration

Cylinder Type:

Style	Description
A01	Air, Aluminum, 4.00" bore and 1/2" NPT ports
A02	Air, Steel, 4.00" bore and 1/2" NPT ports
A03	Custom

Port and Switch Position:

Style	Description
P1	Port Position #1, Switch Position #3
P2	Port Position #2, Switch Position #4 (shown in dwg.)
P3	Port Position #3, Switch Position #1
P4	Port Position #4, Switch Position #2

Switch Option:

Style	Description
C1	Proximity Switches (2)
R1	Reed Switches (2) (Used with an aluminum cylinder with magnetic piston)
N1	No Switches

Arm #1 Option:

Style	Description
AS51	Solid
AS52	Mounting Holes (shown in drawing)
AS53	Custom

Arm #2 Option:

Style	Description
AT51	Solid
AT52	Mounting Holes (shown in drawing)
AT53	Custom

* Complete part number will be acknowledged on quote

* An ALADCO® check valve is recommended to prevent the loss of clamping force if the air supply is interrupted

Aladco.com

1100B South Prairie Avenue | 262-544-5994
Waukesha, WI 53186

